

1	20885		32x190x2916 mm	x1
2	20886		32x190x2916 mm	x1
3	20870		27.6x220x735 mm	x9
4	20871		27.6x220x735 mm	x1
5	20882		65x65x775.5 mm	x1
6	20884		32x245x897 mm	x1
7	20883		32x261x907 mm	x1
8	20862		27.6x482x735 mm	x1
9	20863		27.6x486x1019 mm	x1
10	20864		27.6x489x735 mm	x1
11	70243		5x17x1850 mm	x4
12	70242		8x17x1850 mm	x4
13	70244		5x8x4000 mm	x2
14	70244		21x29x221 mm	x1
15	70244		45x90x640mm	x1

A	72035		Ø4x30 mm	x8
B	72135		Ø6x50 mm	x28
C	72534		Ø6x70 mm	x1
D	72066		Ø6x100 mm	x2
E	72533		Ø6x80 mm	x2
F	72532		Ø7x70 mm	x2
G	70339		M8	x2
H	72356		M8	x2
I	70841		Ø35	x2
J	70850		Ø15	x2
K	70849		Ø12	x2
L	70244		Ø3x15 mm	x8
M	72136		Ø19x18 mm -M8	x12
N	72529		M8x25 mm	x6
O	70353		3x73x204 mm	x1
P	70848		3x65x103 mm	x1
Q	70844		3x72.5x204 mm	x1
R	70845		3x72.5x204 mm	x1

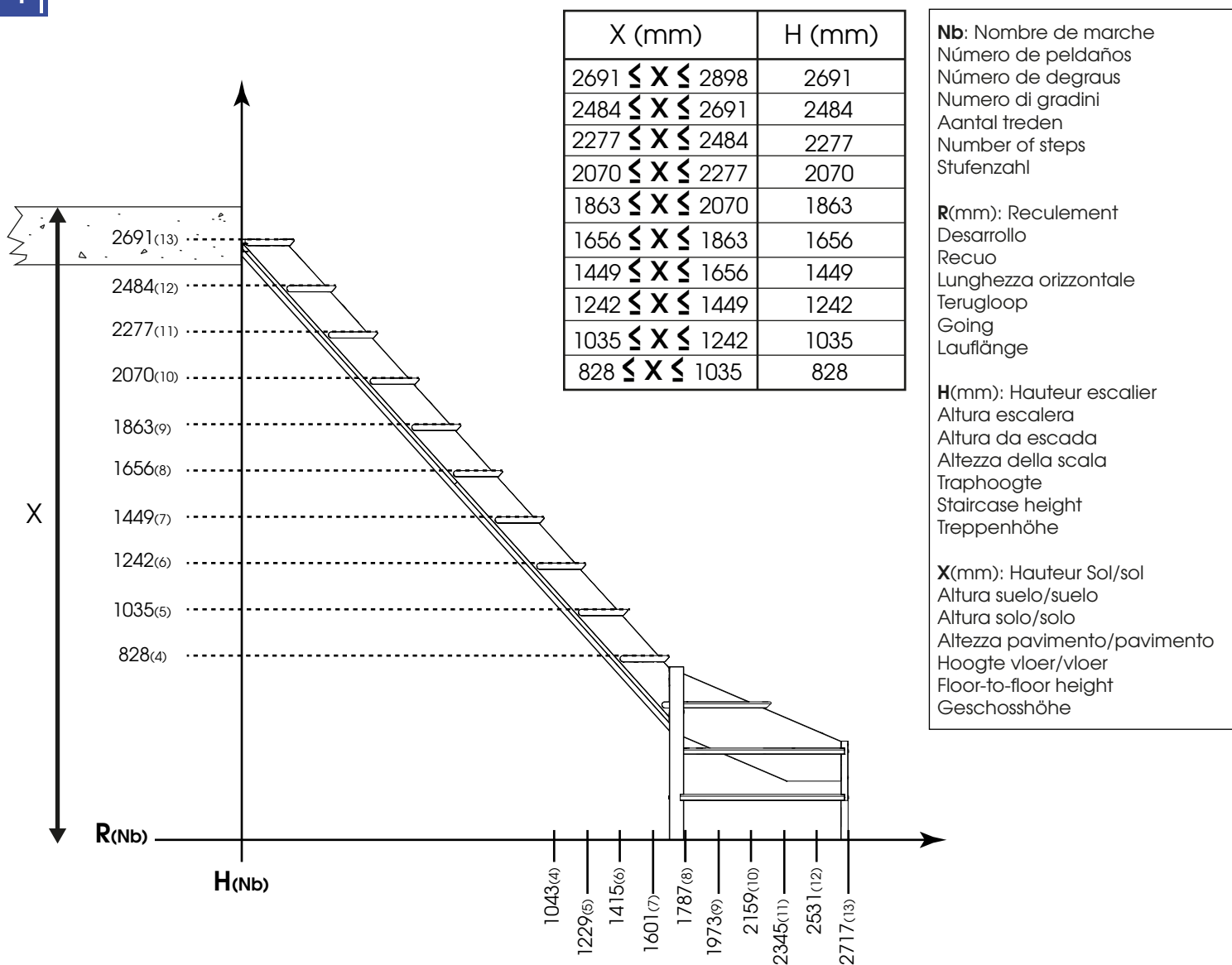

Prendre en compte les deux positions possibles des platines pour choisir la hauteur des points de fixation en haut de l'escalier.

Tener en cuenta las dos posiciones posibles de las placas para elegir la altura de los puntos de fijación en lo alto de la escalera.

Tet em conta as duas posições possíveis das placas para determinar a altura dos pontos de fixação no topo da escada.

Per definire l'altezza dei punti di fissaggio nella parte superiore della scala, considerare le due possibili posizioni delle piastre.

Bij het kiezen van de hoogte van de bevestigingspunten bovenaan de trap moet u ermee rekening houden dat de platen twee mogelijke posities kunnen innemen.

Take into account the two possible positions of the plates when choosing the heights of the fastening points at the top of the staircase.

Berücksichtigen Sie die beiden möglichen Positionen der Fußplatten, um die Höhe der Befestigungspunkte am oberen Ende der Treppe zu wählen.

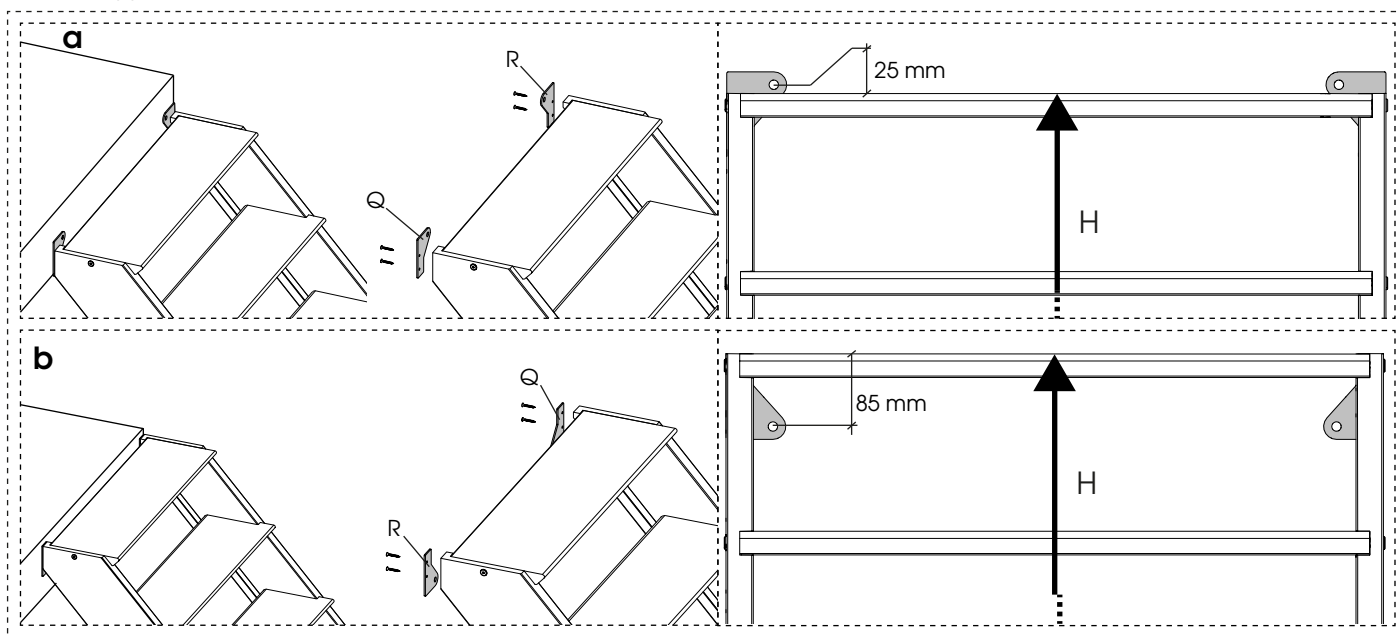

H (mm)	
2691	-
2484	9
2277	8
2070	7
1863	6
1656	5
1449	4
1242	3
1035	2
828	1

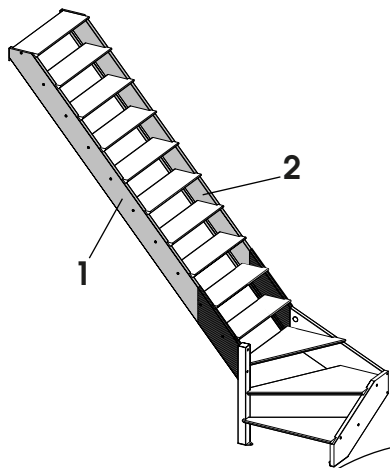

Protéger le limon avec du scotch avant de le scier

Proteja la zanca con cinta antes de serrar o cortar

Proteger a langorina com fitacola antes de serrar

Proteggere il lato con l'adesivo prima di segare

Bescherm de trapboom met tape vooraleer deze te zagen

Protect the string board with scotchtape before sawing it

Treppenwange mit Tesafilm schützen bevor zu sägen

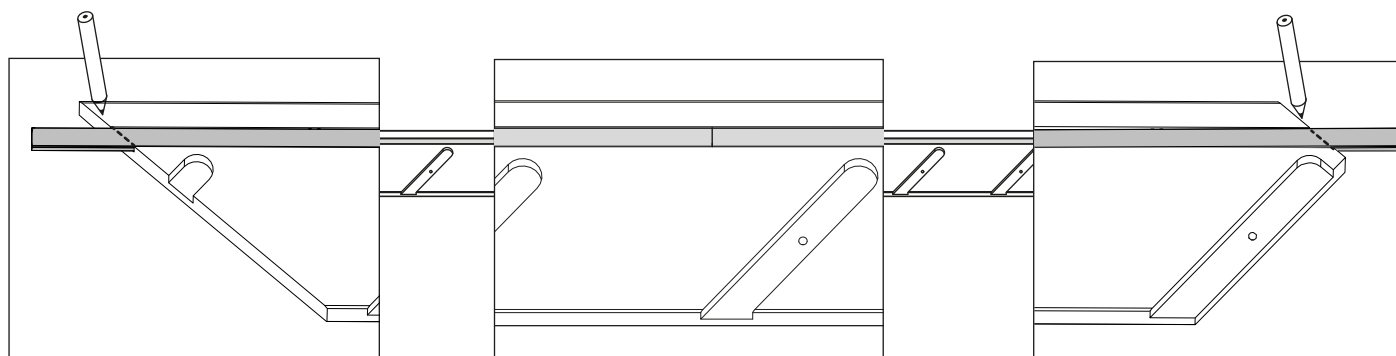
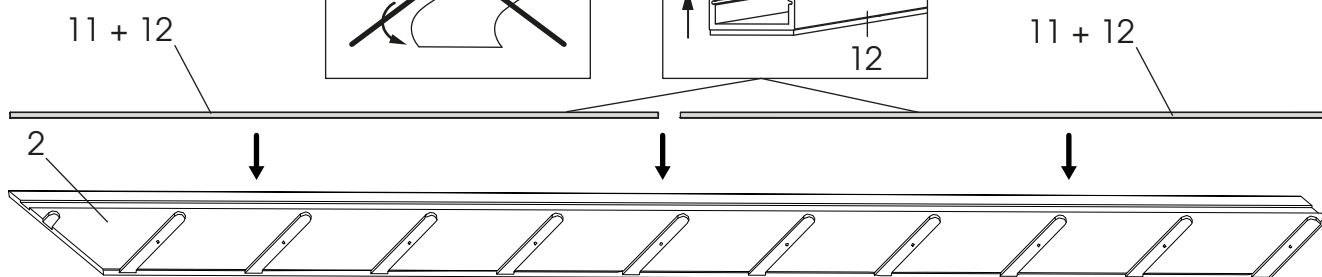
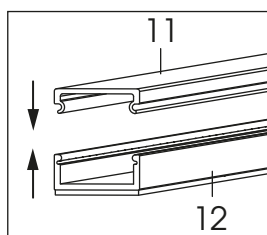
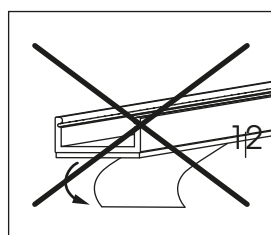
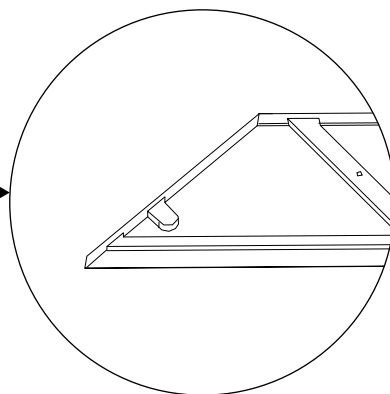
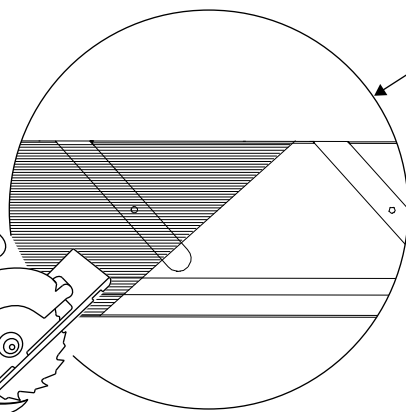
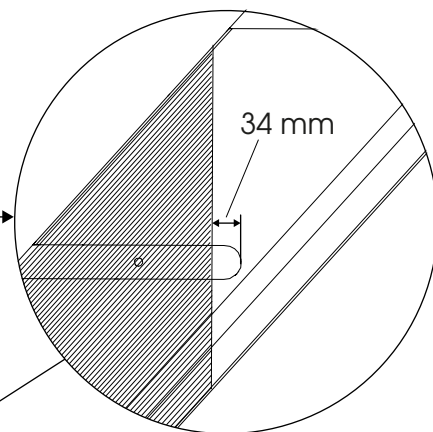
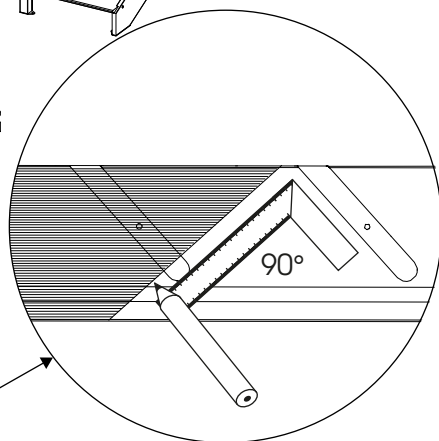
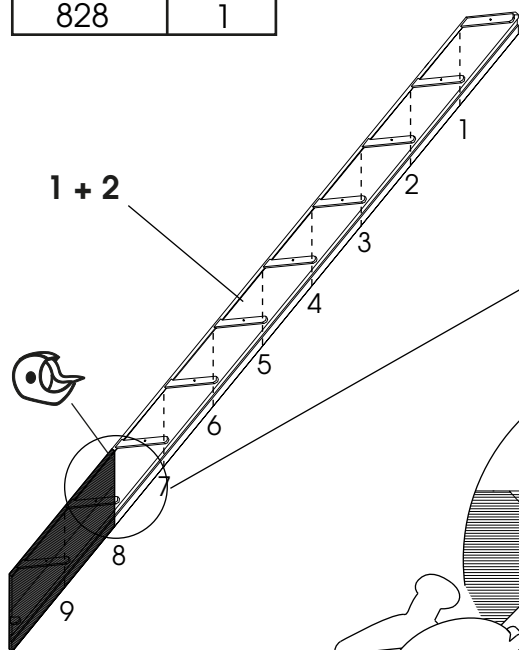

4

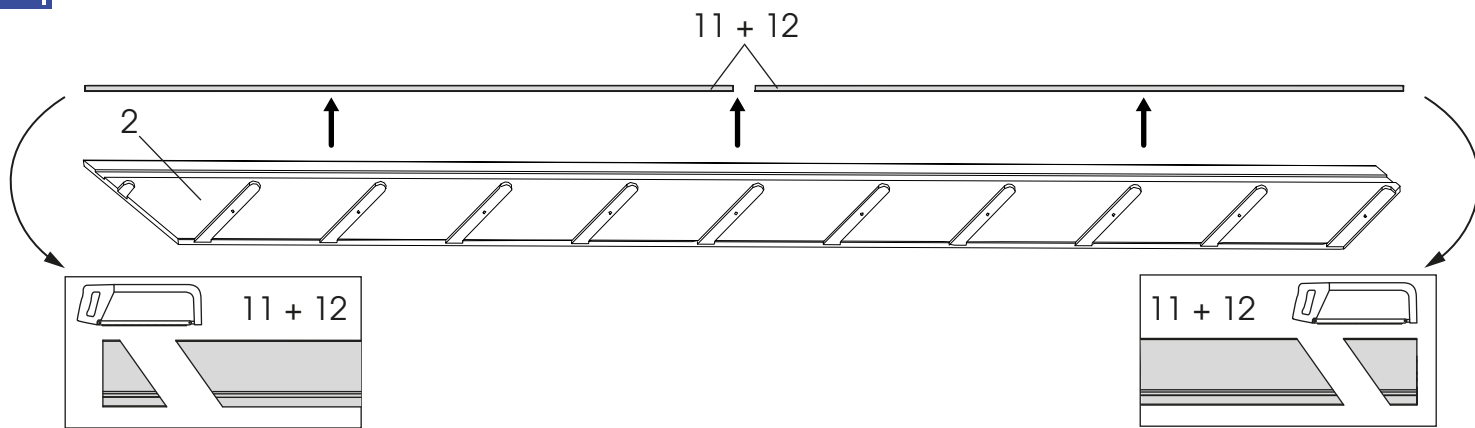

5

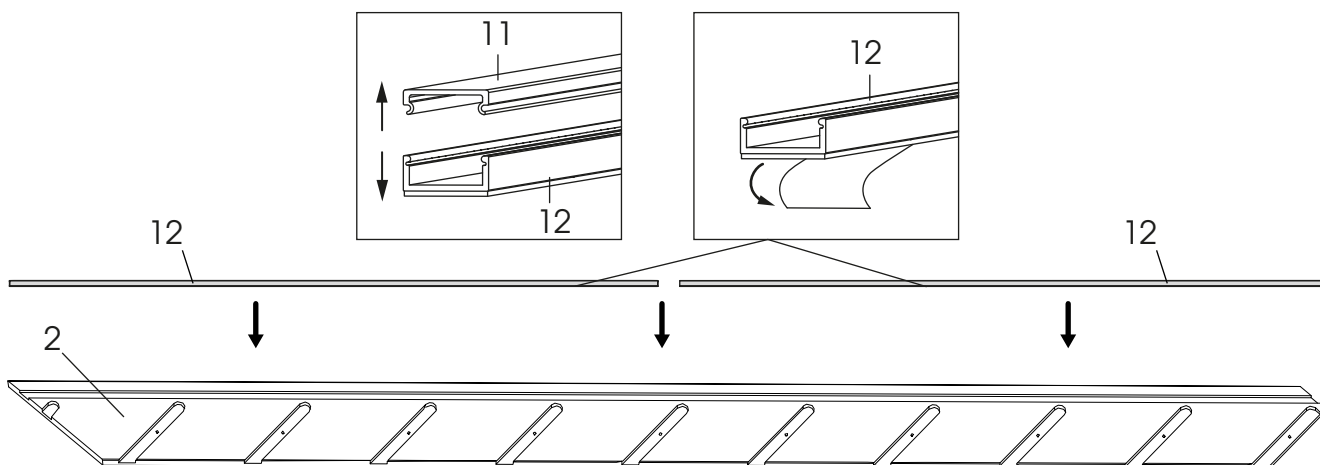

6

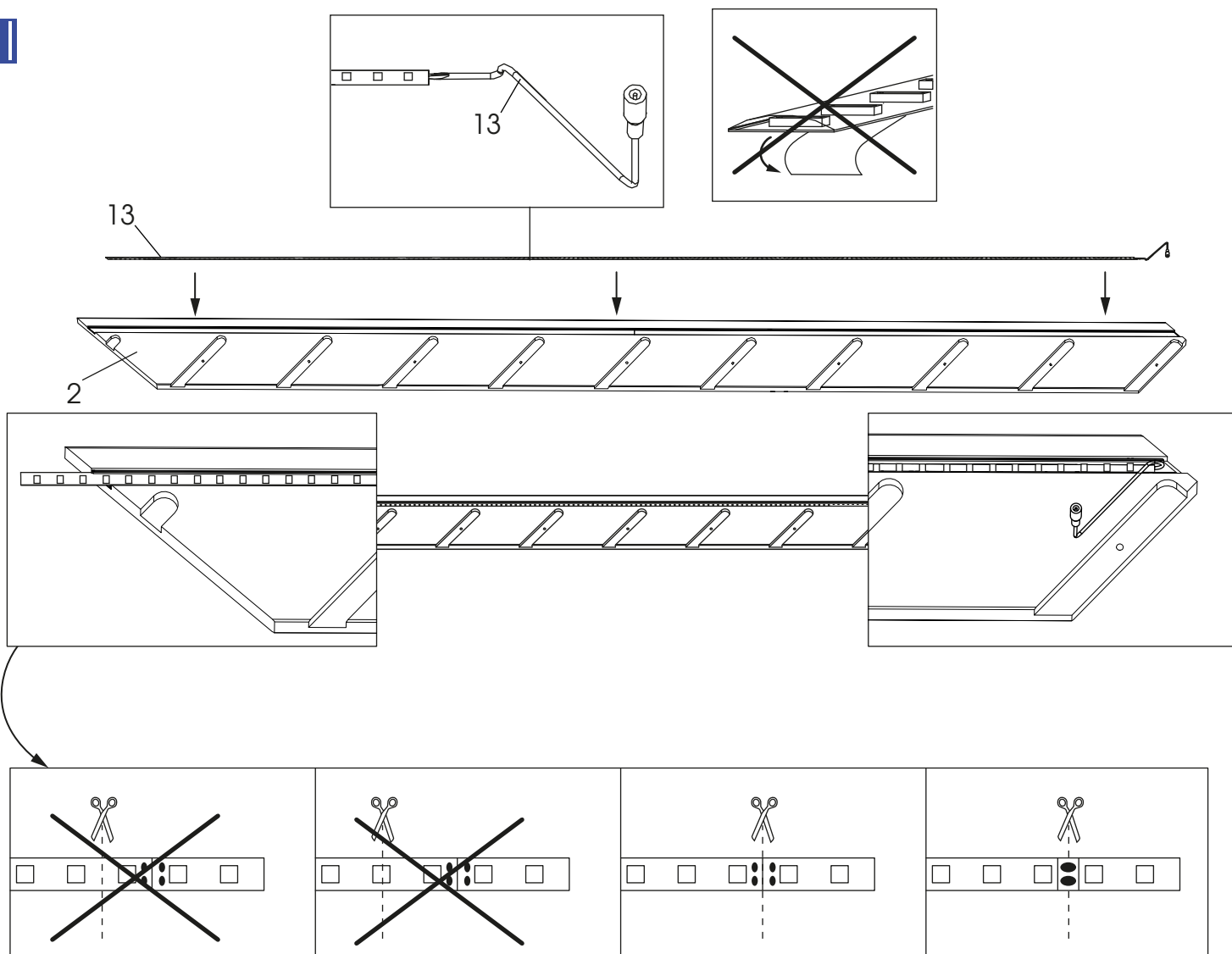

7

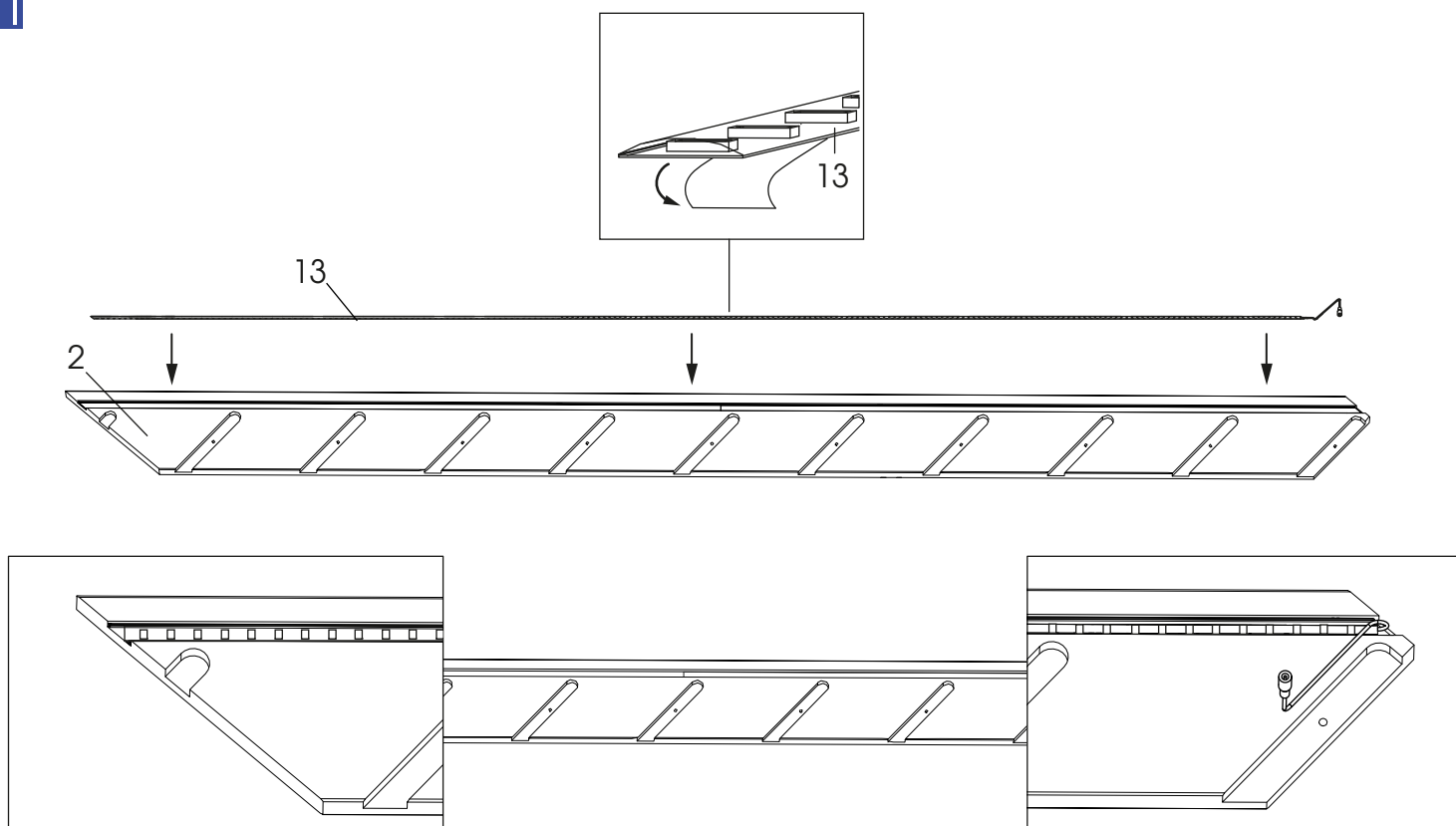

8

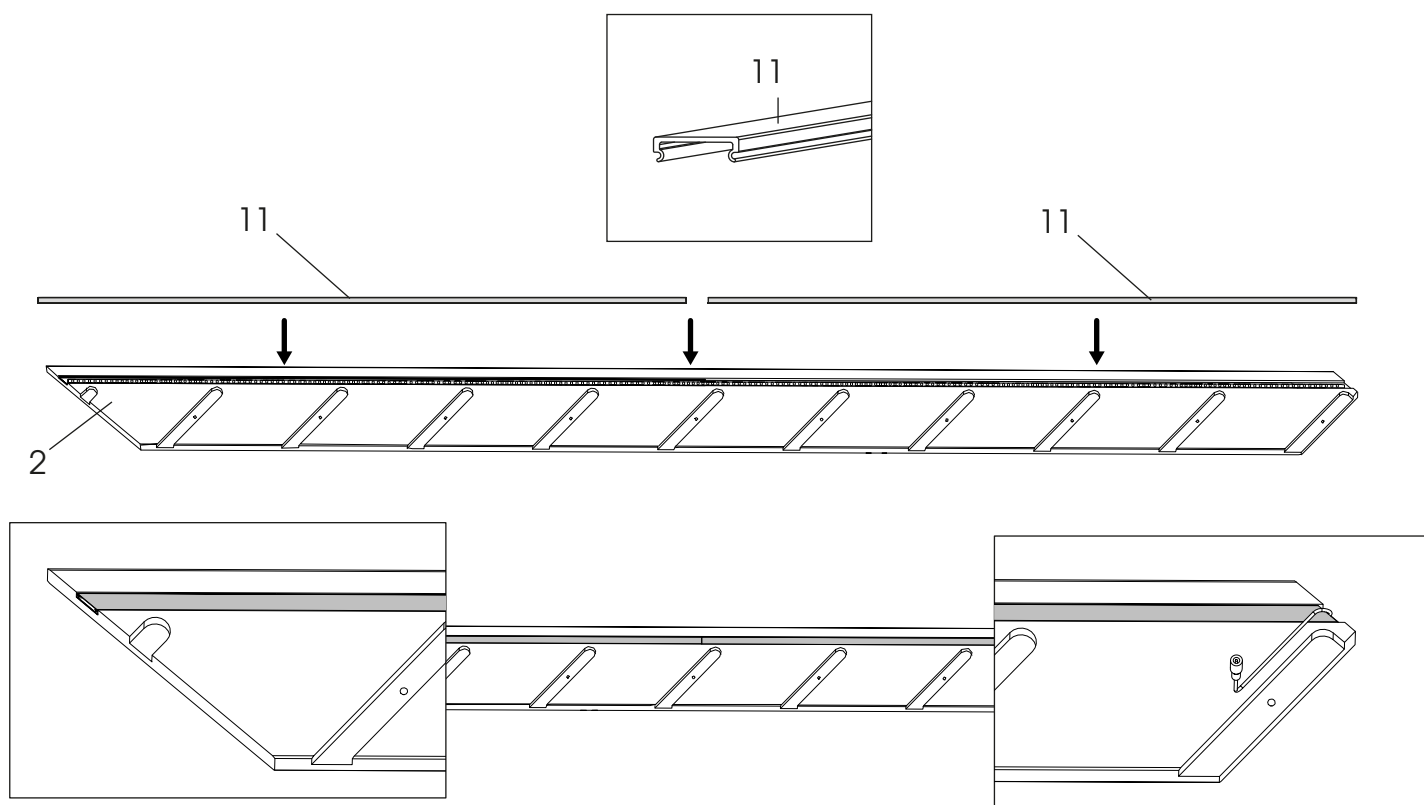

9

Reprendre les étapes 3 à 8 pour le limon 1

Repita los pasos 3 a 8 para la zanca 1

Repetir os passs 3 a 8 para a longarina 1

Ripetere le tappe 3 a 8 per il lato 1

De stappen 3 tot 8 herhalen voor trapboom 1

Come back to the steps 3 to 8 for string board 1

Wiederholen Sie die Schritte 3 bis 8 für Wange 1

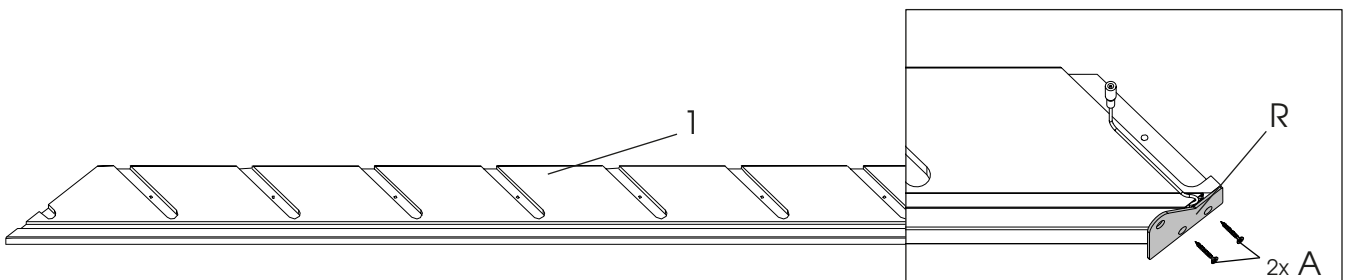
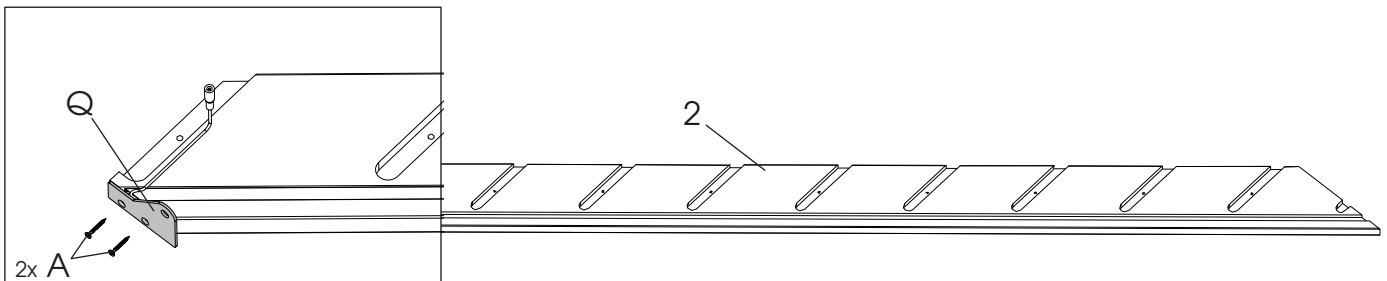
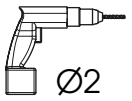
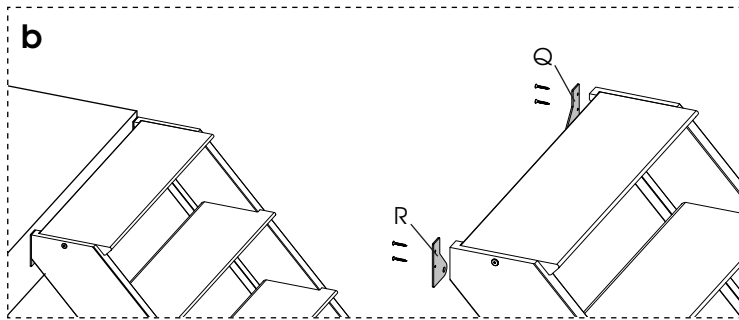
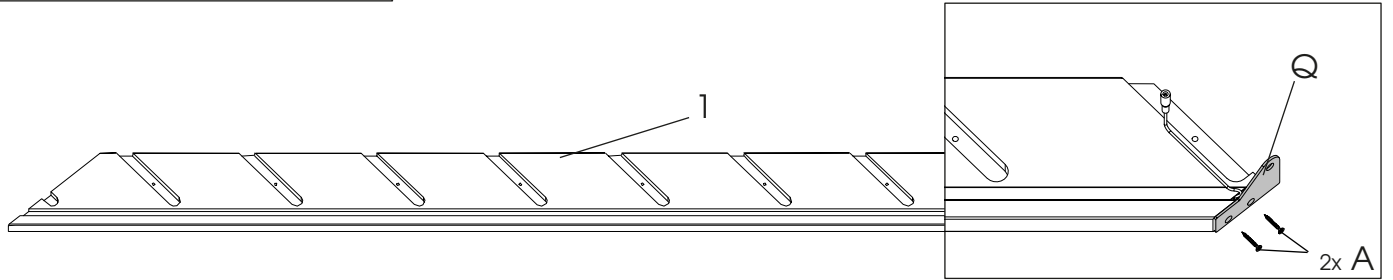
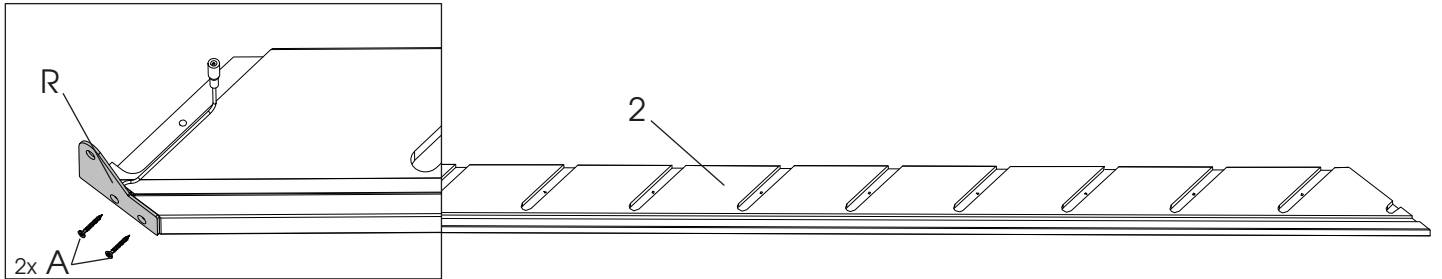
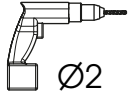
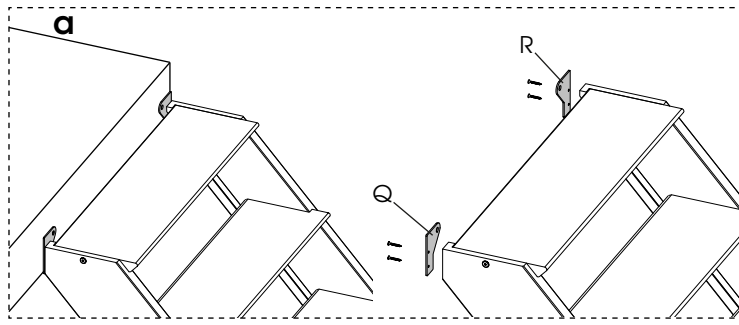

11

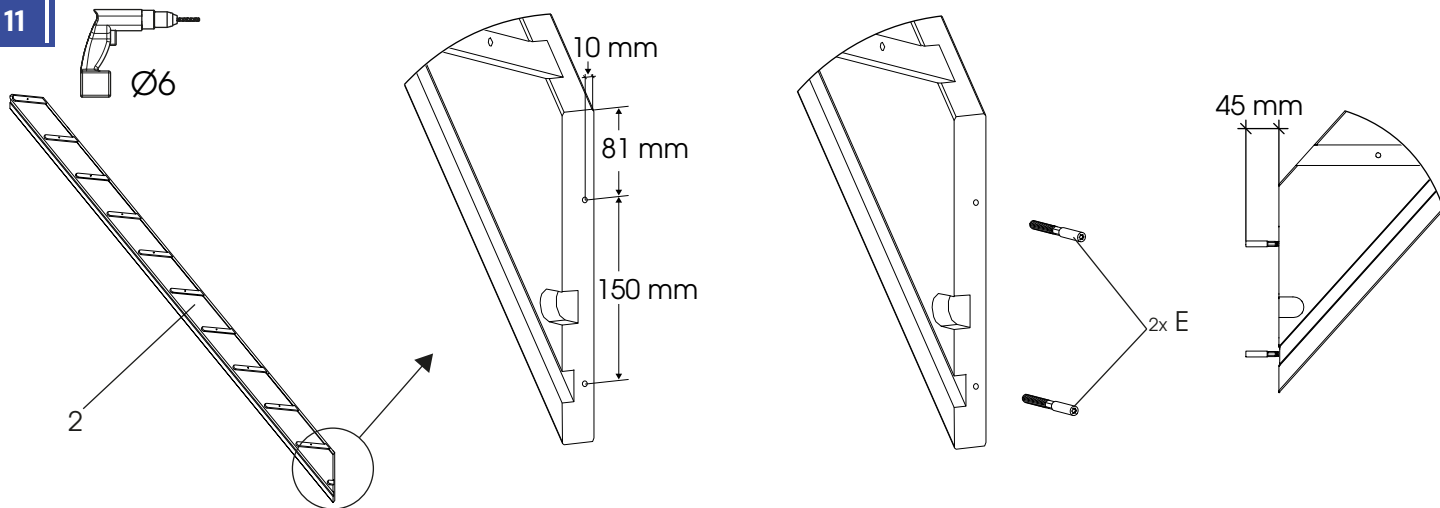

12

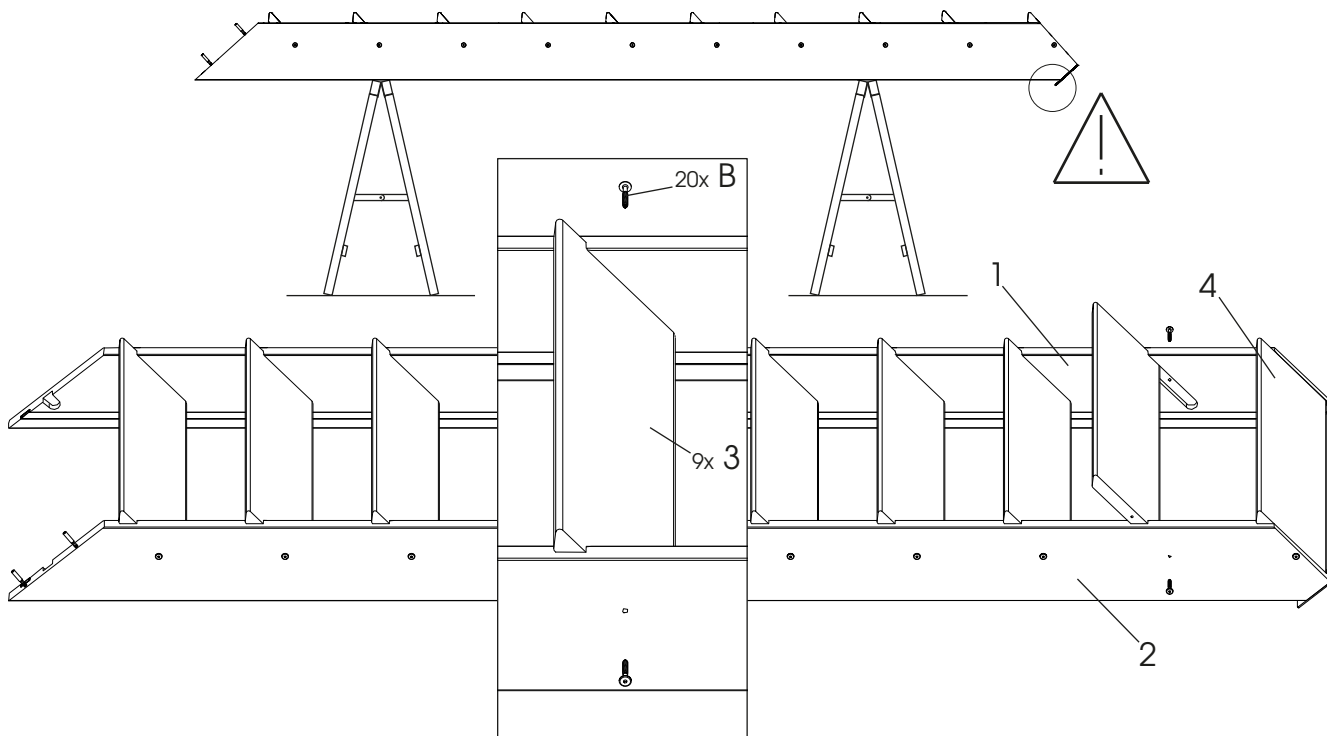

13

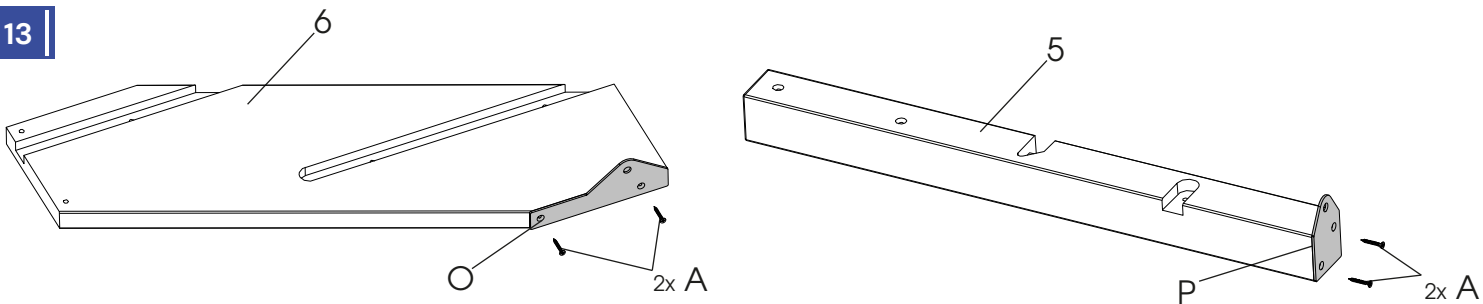

14

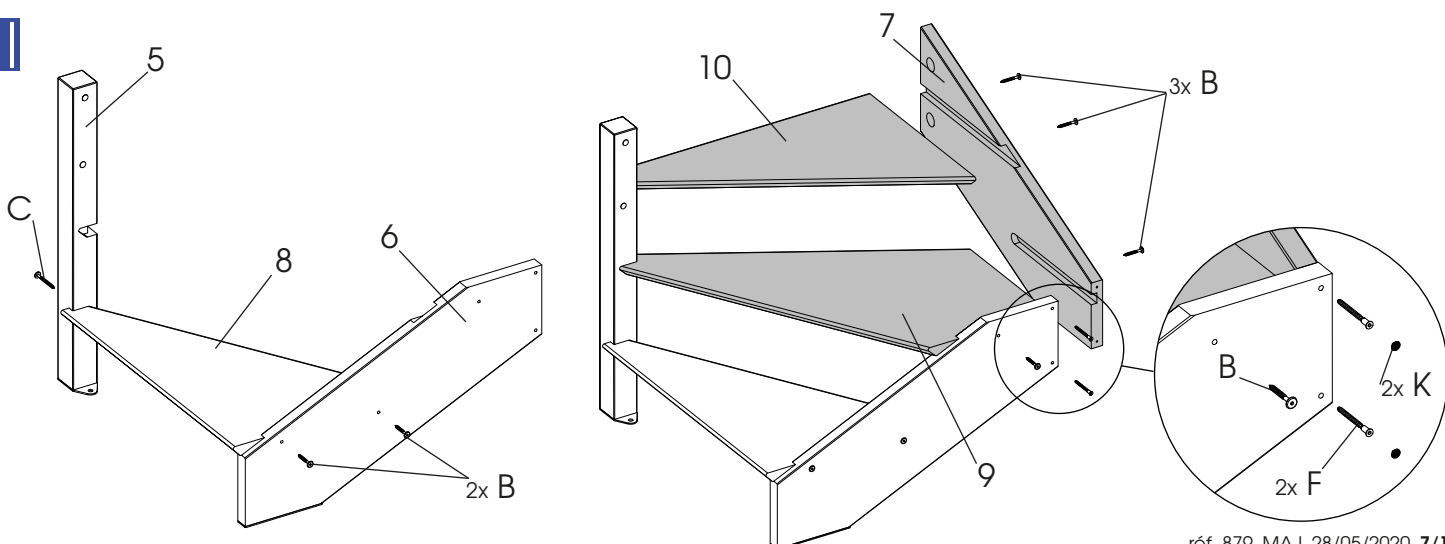

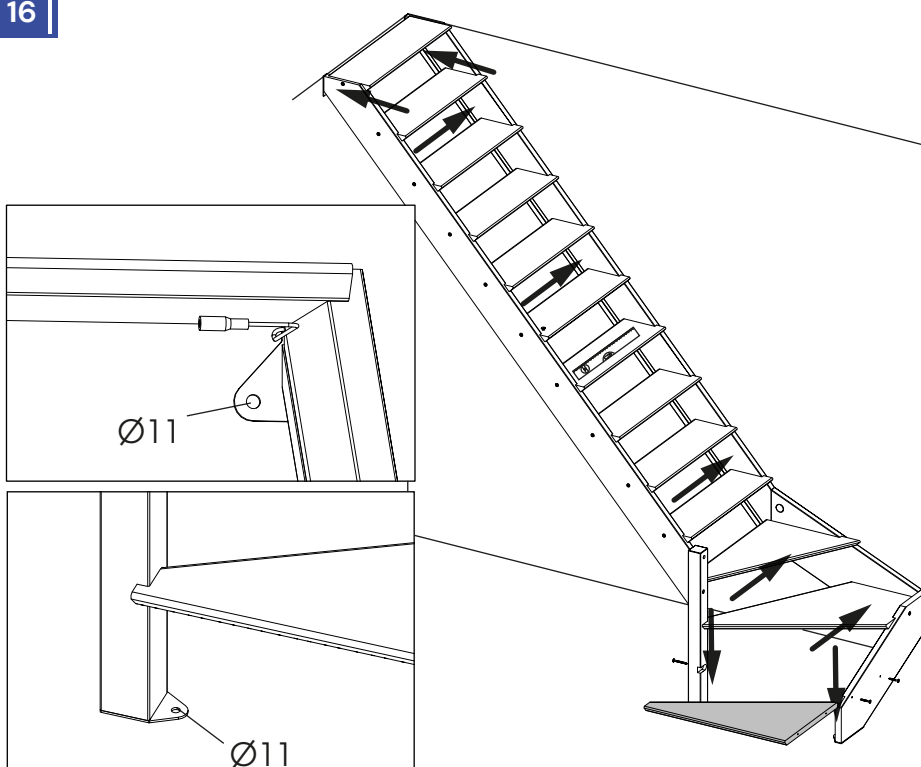
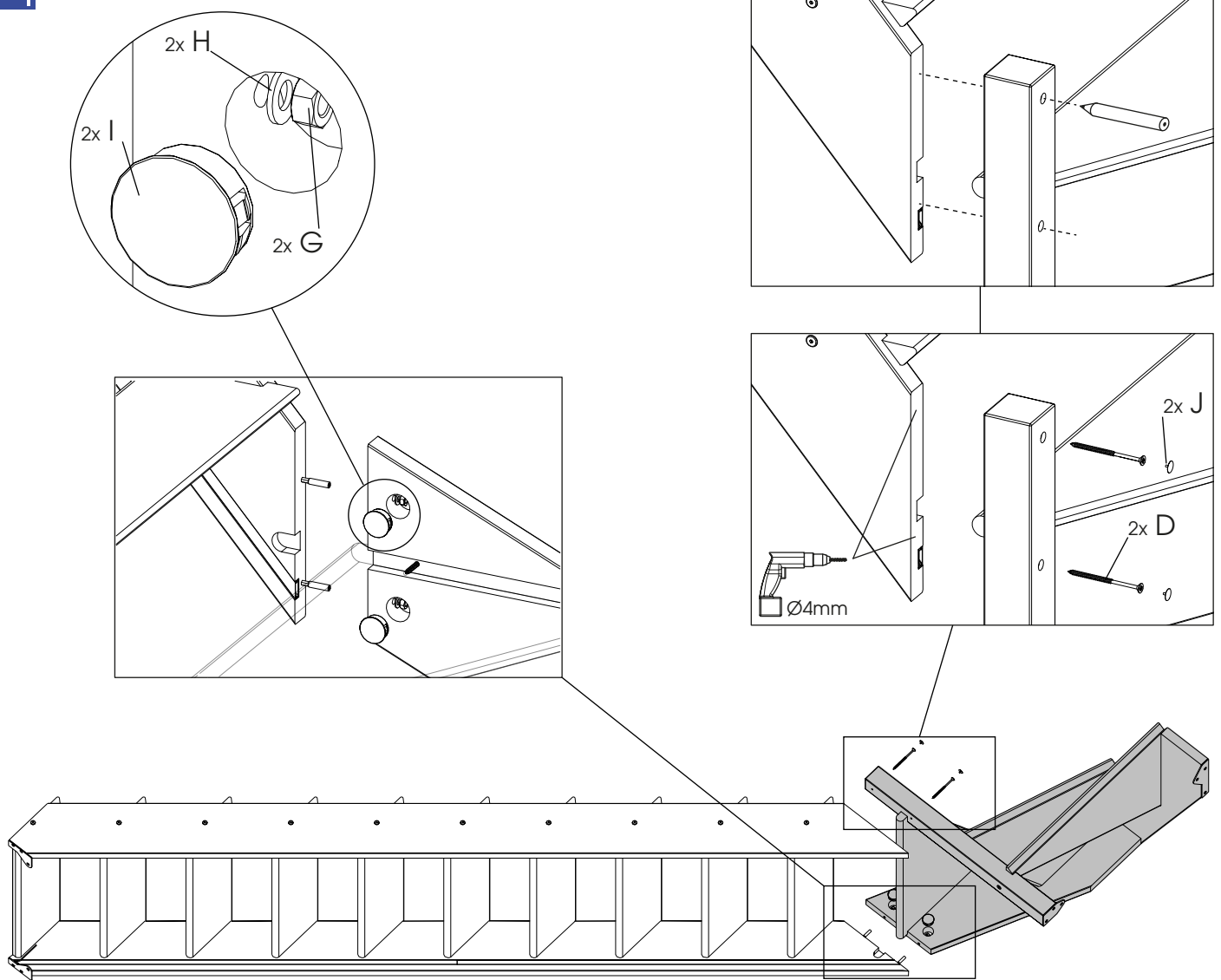

Fixer l'escalier à la dalle et au mur avec des accessoires d'ancrage adaptés.

Fijar la escalera a la losa y al muro con accesorios de anclaje adaptados.

Fixar a escada na laje e na parede com os acessórios de ancoragem adaptados.

Fissare la scala alla mattonella e al muro con gli appositi elementi di ancoraggio.

Bevestig de trap met de geschikte bevestigingsaccessoires aan de plaat en de muur.

Fasten the staircase to the floor and wall using suitable fastening accessories.

Befestigen Sie die Treppe mit dem passenden Verankerungszubehör an der Bodenplatte.

Si vous avez choisi l'option «Télécommande», reportez-vous à la notice de la télécommande pour installer le récepteur à cette étape.

Si ha elegido la opción «Mando a distancia», consulte las instrucciones del mando a distancia para instalar el receptor en esta etapa.

Se tiver escolhido a opção "Controlo remoto", consulte as instruções do controlo remoto para instalar o recetor nesta etapa.

Se avete scelto l'opzione "Telecomando", fare riferimento al manuale del telecomando per installare in questa fase il ricevitore.

Wanneer u koos voor de optie «Afstandsbediening» verwijzen we naar de handleiding voor de afstandsbediening voor de installatie van de ontvanger in deze stap.

If you have selected the optional remote control, please refer to the instructions for the remote control to install the receiver at this stage.

Wenn Sie die Option "Fernbedienung" gewählt haben, lesen Sie in der Anleitung der Fernbedienung nach, um den Empfänger in diesem Schritt zu installieren.

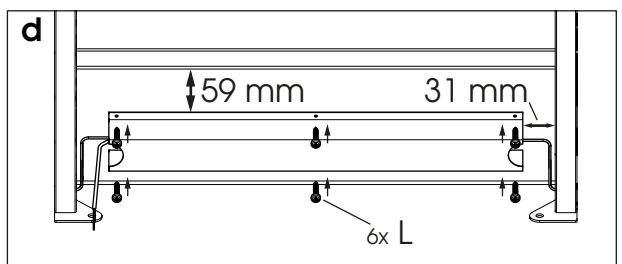
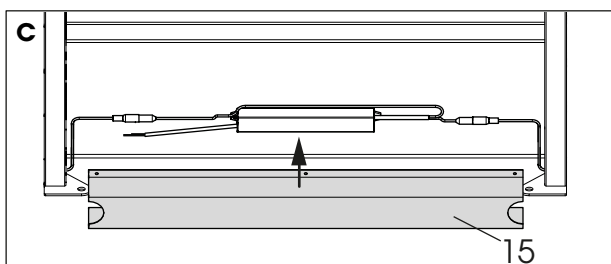
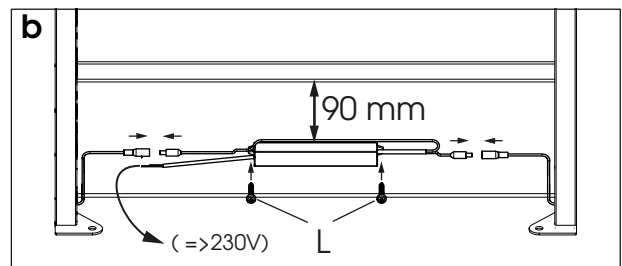
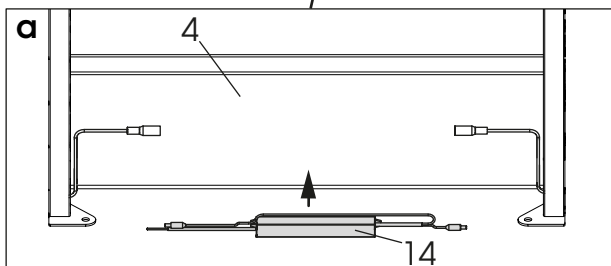
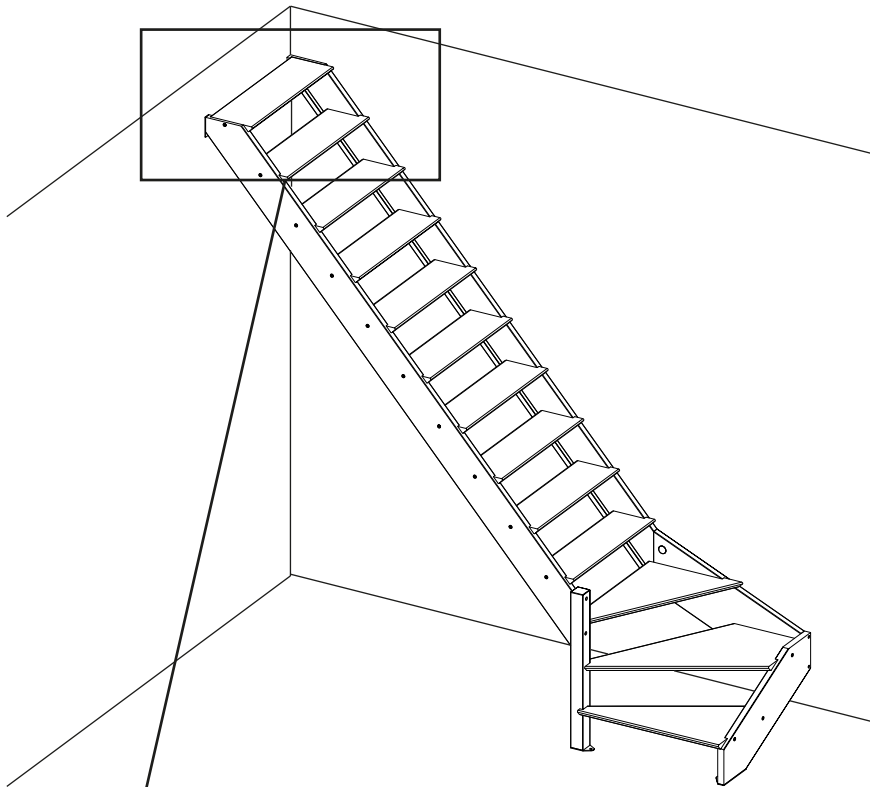

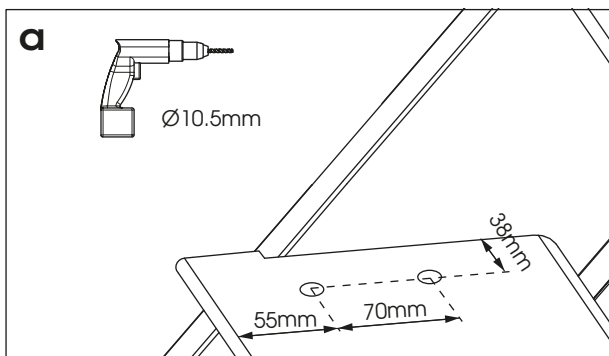

 Ne pas détériorer les câbles électriques
 No dañar los cables electricos
 Não danificar os cabos electricos
 Non deteriorare i cavi elettrici
 De elektriciteitskabels niet beschadigen
 Don't damage the electric cables
 Elektrische Kabel nicht beschädigen

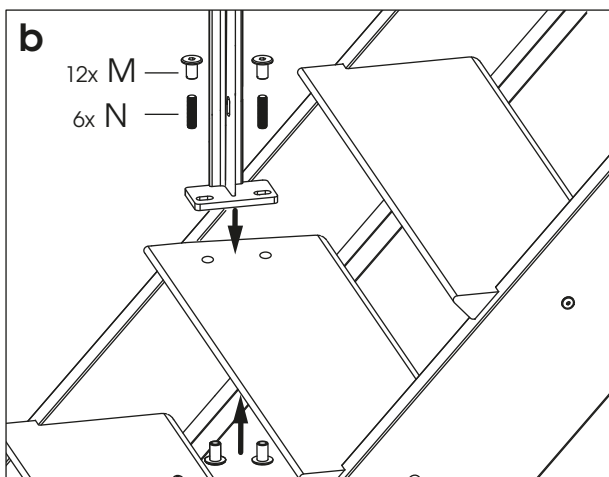

Poursuivre le montage en vous reportant à la notice fournie avec le rampant
 Continuar el montaje siguiendo las indicaciones del manual suministrado con " la subida
 Seguir a instalação seguinte as instruções fornecidas com a subida
 Proseguire il montaggio riportandovi alle istruzioni fornite con la salita scala
 Zet de montage voort en kijk hierbij in de handleiding geleverd bij het hellende vlak
 Go on with the montage reading the instructions provided with the stairwells
 Setzen Sie die Montage dank der mit dem Treppengeländer gelieferten Anleitung fort



IMPORTANT, A CONSERVER POUR CONSULTATION ULTERIEURE
 Référence à communiquer
 pour toute demande

IMPORTANTE, CONSERVAR PARA CONSULTAR POSTERIORMENTE
 Referencia que se debe adjuntar
 a cualquier petición

IMPORTANTE CONSERVAR PARA FUTURAS CONSULTAS
 Referência a comunicar
 para qualquer pedido

IMPORTANTE, DA CONSERVARE PER ULTERIORE CONSULTAZIONE
 Riferimento da comunicare
 per qualunque richiesta

BELANGRIJK ! BEWAREN VOOR LATER !
 Referentie te vermelden
 bij elke communicatie

IMPORTANT, TO BE RETAINED FOR FUTURE REFERENCE
 reference to communicate
 for any request

WICHTIG, FÜR SPÄTERE EINSICHTNAHME AUFBEWAHREN
 Artikelnummer bei jeder Anfrage angeben

Rampant SPARK ou UNIVERSO

Subida SPARK O UNIVERSO

Subida SPARK ou UNIVERSO

Salita scala SPARK o UNIVERSO

Hellend vlak SPARK of UNIVERSO

Stairwells SPARK or UNIVERSO

Treppengeländer SPARK

oder UNIVERSO

